

LOC	DIST	REVISIONS					
CM	00	P	LTR	DESCRIPTION	DATE	DWN	APVD
		D		ECO-07-007260	09APR07	KW	DB

DIMENSION IN BRACKET ARE IN INCHES.

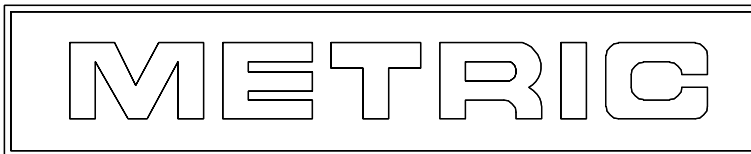
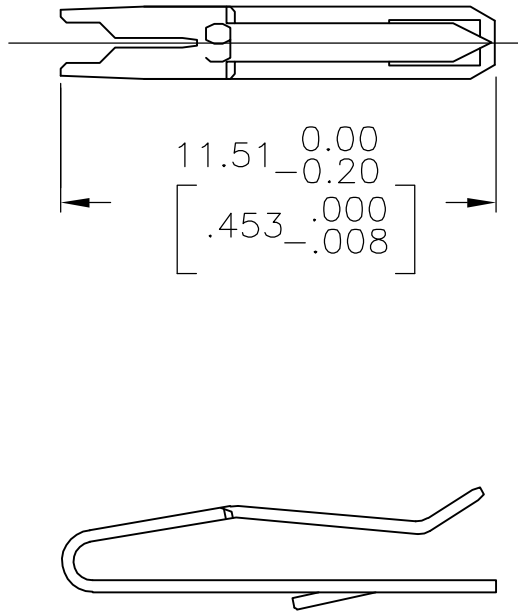

TIN	641645-2
TIN-LEAD	641645-1
FINISH	PART NO

RELEASED FOR PUBLICATION

ALL RIGHTS RESERVED.

BY TYCO ELECTRONICS CORPORATION.

THIS DRAWING IS UNPUBLISHED.

© COPYRIGHT

DIMENSIONS: mm [INCHES]	DWN L. SMITH 20JAN94	MATERIAL 0.30[.012] THK COPPER ALLOY	FINISH MATTE TIN OR BRIGHT TIN LEAD 0.00203[.000080] MIN THK
	CHK R. SWING 20JAN94	Tyco Electronics Corporation Harrisburg, PA 17105-3608	
TOLERANCES UNLESS OTHERWISE SPECIFIED:	APVD E. BEILES 27JAN92	NAME CONTACT, 0.36-0.51 [.014-.020] POST LOOSE PEICE 26 AWG WIRE, MTA-100	
	PRODUCT SPEC -	SIZE A4	CAGE CODE 00779
0 PLC ± -	APPLICATION SPEC -	DRAWING NO C-641645	RESTRICTED TO -
1 PLC ± -	WEIGHT -		
2 PLC ± -		SCALE 5:1	SHEET 1 OF 1
3 PLC ± -		REV D	
4 PLC ± -			
ANGLES ± -			

